

Ra 3.2 / ( )

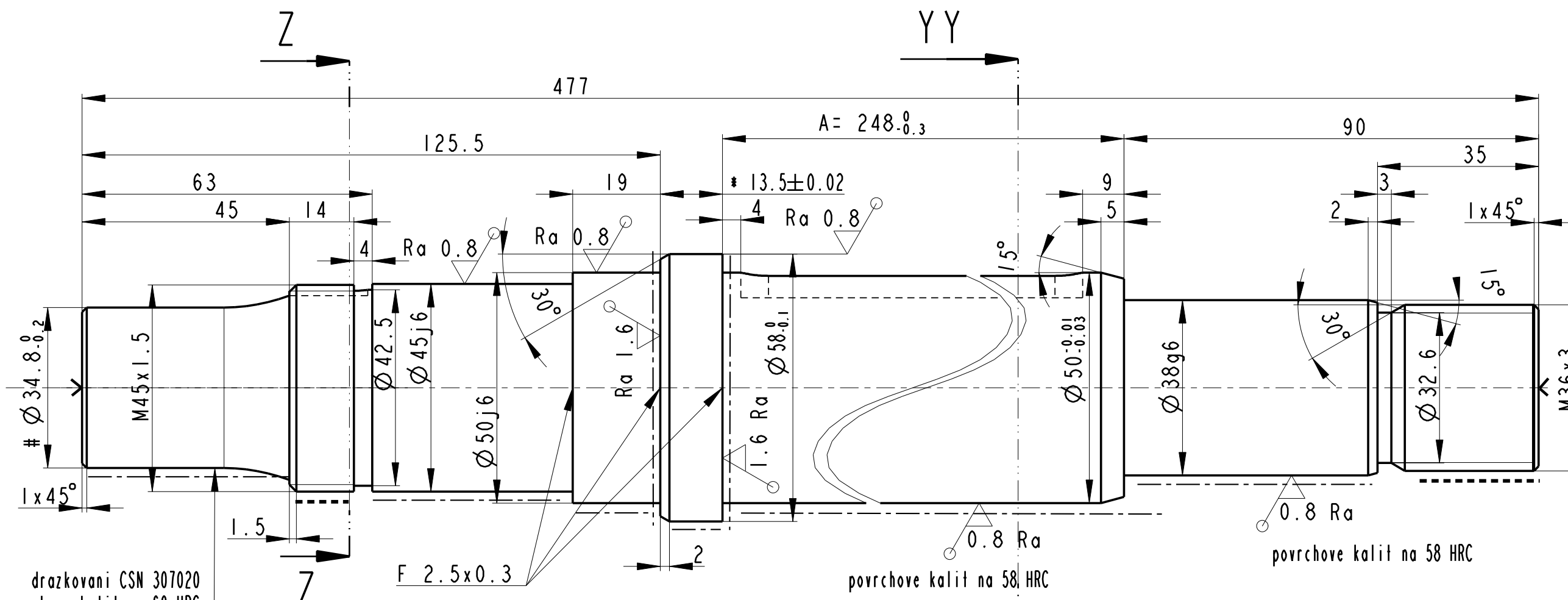

drážkovani CSN 307020  
povrchove kalit na 60 HRC

povrchove kalit na 58 HRC

povrchove kalit na 58 HRC

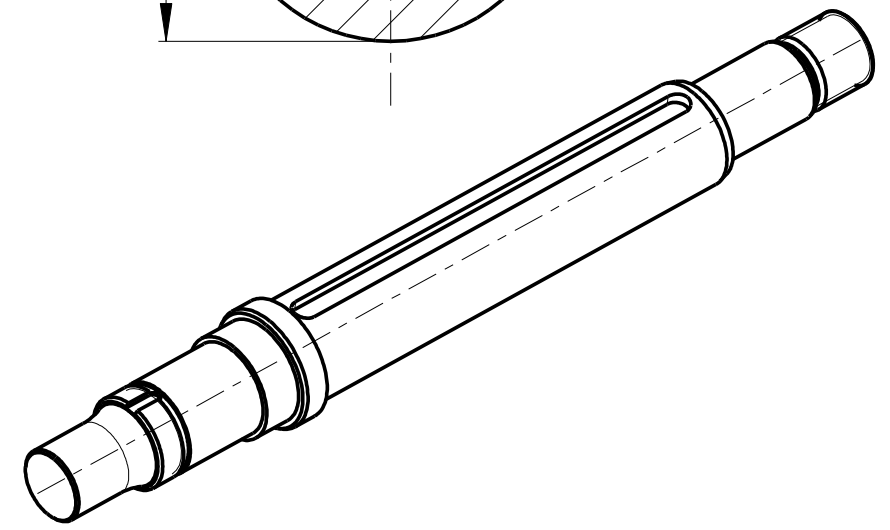
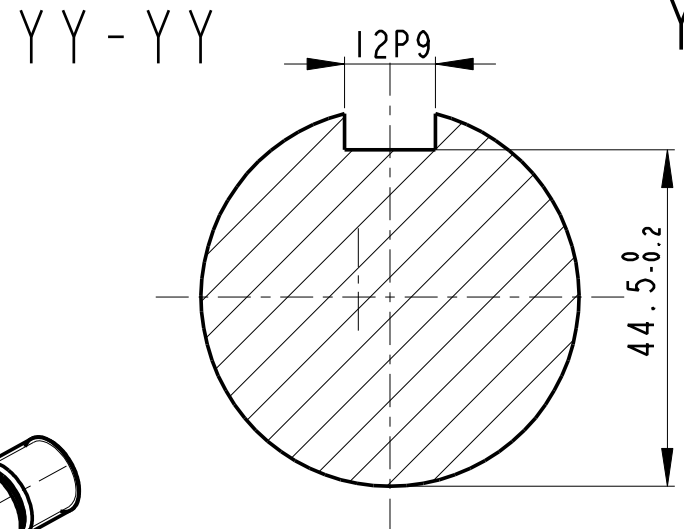
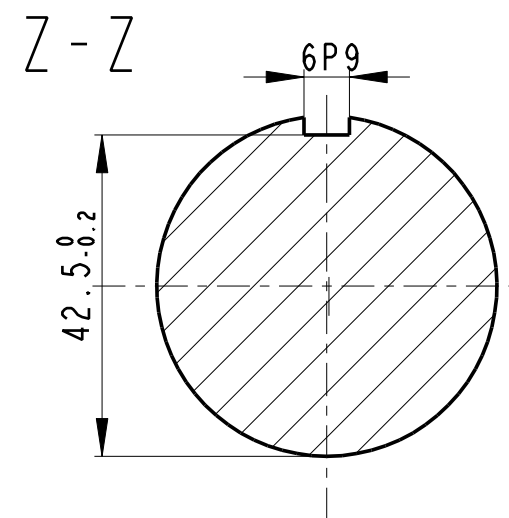

3:10

----- PRIDAVEK POD ZAVIT 1 mm

----- PRIDAVEK NA BRUS  
- POVRCH 0.3 mm  
\*) - CELO 0.05 mm

Zuslechtit na Rm=650 - 840 MPa  
# - upravit dle CSN 30 7020  
ISO 2768 mK

- Ø60-607		--	12050	---	---	6.900			7
Mn	Nazev-Rozmer	Polotovar	Mat.kon.	Mat.vych.	TO	C.hm.	H.hm.	Cislo vykresu	Poz.
Pozn.									
Meritko	Kreslil	Cervinka	C.snimku	PZB Kovona					x
:	Prezkoušel		C.transp.	Zmena		Datum	Podpis		x
	Norm.referent								x
	Vyr.projed.	Schválil							x
		Dne 01.11.05							x
Typ		SP27S-000			Nový výkres				
Název		SWAH HRIDEL A250/Ø50			SP27S-007-3/250				
List									