

NORMAL TOOTH PROFILE VIEW
GOST 9324-80
B (5 : 1)

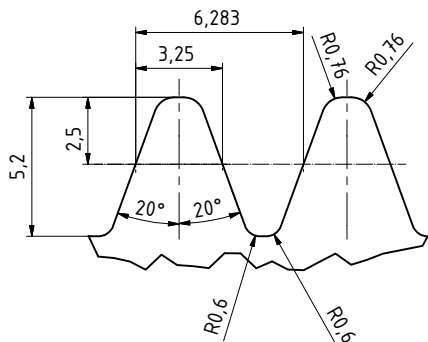

SPECIFICATIONS HOB CUTTER		СПЕЦИФИКАЦИИ ЧЕРВЯЧНОЙ ФРЕЗЫ	
PARAMETER CUTTER	ПАРАМЕТР ФРЕЗЫ	VALUE	ЗНАЧЕНИЯ
MODUL	МОДУЛЬ	2.0	
GNPA	УГОЛ ЗАЦЕПЛЕНИЯ	20°	
NO. THDS	ЧИСЛО ЗАХОДОВ	1	
HAND	НАПРАВЛЕНИЕ НАРЕЗКИ	RIGHT	
NCP	ШАГ ВИТКА ПО НОРМАЛИ	6.2832	
ACP	ШАГ ВИТКА ПО ОСИ	6.2873	
TOLERANCES CLASS HOB CUTTER DIN 3968 КЛАСС ТОЧНОСТИ DIN 3968		AA	
LEAD ANGLE	УГОЛ ПОДЪЕМА ВИТКА	2°05'02"	
NO. GASHES	ЧИСЛО СТРУЖЕЧНЫХ КАНАВОК	12	
GASH HAND	НАПРАВЛЕНИЕ СТРУЖЕЧНЫХ КАНАВОК	STRAIGHT	
GASH LEAD	ШАГ СТРУЖЕЧНЫХ КАНАВОК	--	
CAM	ЗАТЫЛКОВКА	2.49(3.34)	

ONLY FOR INFORMATION

Approximate weight tools 0.7 kg

Rev	Date	Prep. by	Note	Customer:	Scale:
①					1 : 1
②				In. code:	
③				Number of drawing:	Size:
④				Type of cooling:	A3
⑤				Type of coating:	N. edge:
⑥				Semiproduct:	12
				Date:	12.06.2020
				Drew:	Klus
				Description:	
				Category:	
				Number of drawing:	Index: